

KWE-96-19"Schublade mit Tastatur

2HE, 19" drawer keyboard



Description

Applications:

These keyboards can be used in virtually all fields, where a sealed keyboard is needed such as industry, medicine, aviation, marine and military.

Characteristics:

- The drawer is IP65/NEMA4 water and dust proof with deployed or retracted keyboard.
- The keyboard and its drawer fit perfectly into the slot of a 19" rack with the height of 2HE
- The patented keyboard housing is very sturdy and modern in design.
- The short-travel keys offer positive tactile feedback.

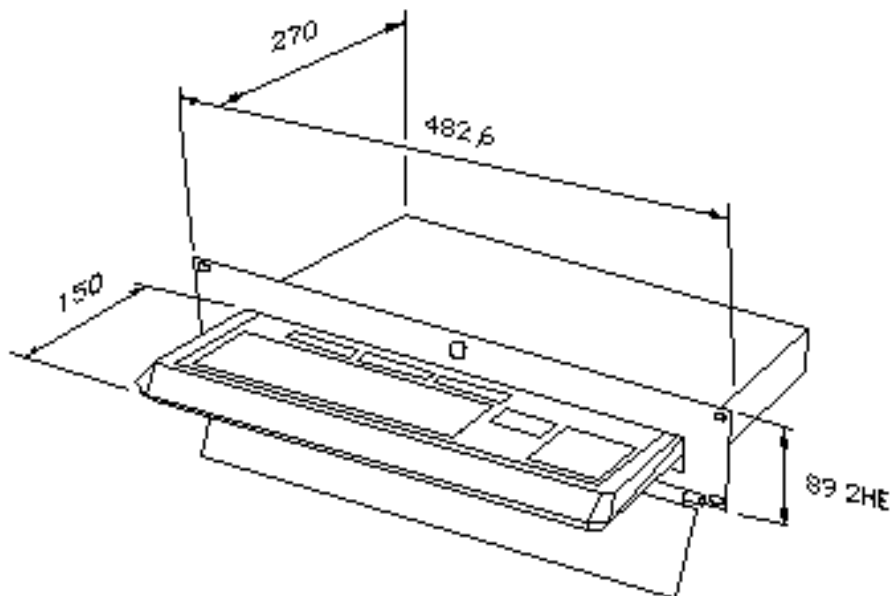

Specification

Mechanical data

Dimensions: 482,6 x 270 x 89 mm
Housing: Metal
Degree of Protection: IP65
Color: black

Keys

Key Technology: short travel key
Number of Keys: 92
Keyboard Layout: MF2-German
Operational Life: 1 mio. keystrokes min.
Key Legend: silk screen

Electric Data

Interface: [PS/2](#)
Operating Voltage: $5 \pm 0,25$ V
Operating Current: 170 mA

Environment

Operating Temperature: from -20 °C to +70 °C
Storage Temperature: from -40 °C to +85 °C

Order Information

Order No.	Article	
KW1037	KWE-96-Schub-PS2-Ger	PS/2 interface, german layout
KW1038	KWE-96-Schub-PS2-US	PS/2 interface, US layout

Accessories

Order No.	Article	
ZK1029	COM 9255	adapter PS/2 to AT



sales@www.tastaturen.com Anrufen: (0 89) 89 43 99-0 Faxen: (0 89) 89 43 99-11